

M500FP Firephone Control Module

Specifications

Normal Operating Voltage:	15 to 32 VDC
Maximum Current Draw:	6.5mA (LED on).
Average Operating Current:	2.0mA (LED flashing).
Handset Offhook Resistance:	400 to 1,500 Ohms
External Supply Voltage (between Terminals T3 and T4)	
Maximum:	28 Volts DC
Temperature Range:	32°F to 120°F (0°C to 49°C)
Humidity:	10% to 93% Noncondensing
Dimensions:	4 1/2" H x 4" W x 1 1/4" D (Mounts to a 4" square by 2 1/8" deep box.)
Accessories:	SMB500 Electrical Box; CB500 Barrier

Before Installing

This information is included as a quick reference installation guide. Refer to the control panel installation manual for detailed system information. If the modules will be installed in an existing operational system, inform the operator and local authority that the system will be temporarily out of service. Disconnect power to the control panel before installing the modules.

NOTICE: This manual should be left with the owner/user of this equipment.

General Description

M500FP Firephone Control Modules are intended for use in intelligent, two-wire systems, where the individual address of each module is selected using the built-in rotary switches. This module is used to connect a remote firefighter telephone to a centralized telephone console. A ringing sound is provided at each off-hook handset until it is connected to the console. Wiring to individual telephone jacks and handsets is supervised, and status is reported to the panel as NORMAL, TROUBLE, or TELEPHONE. The M500FP has two pairs of output termination points available for fault-tolerant wiring, and includes a panel-controlled LED indicator.

Compatibility Requirements

To ensure proper operation, this module shall be connected to Listed compatible system control panels only.

Mounting

This module mounts directly to 4" square electrical boxes (see Figure 2A). The box must have a minimum depth of 2 1/8". Flush mounted electrical boxes (SMB500) are available.

Wiring

NOTE: All wiring must conform to applicable local codes, ordinances and regulations. When using control modules in nonpower limited applications, the CB500 Module Barrier must be used to meet UL requirements for the separation of power-limited and nonpower-limited terminals and wiring. The barrier must be inserted into a 4"x4"x2 1/8" junction box, and the control module must be placed into the barrier and attached to the junction box (Figure 2A). The power-limited wiring must be placed into the isolated quadrant of the module barrier (Figure 2B).

1. Install module wiring in accordance with the job drawings and appropriate wiring diagrams (Figures 3-4).
2. Set the address on the module per job drawings.
3. Secure module to electrical box (supplied by installer), as shown in Figure 2A.

Figure 1. Controls and Indicators

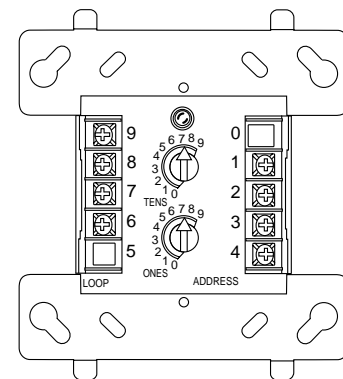

A78-2318-06

Figure 2A. Module mounting with barrier:

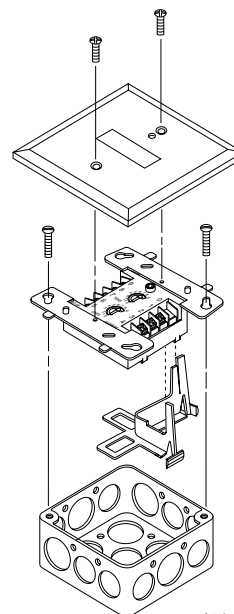

A78-2610-15

Figure 2B:

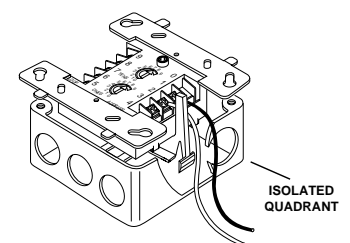

A78-2611-17

Figure 3. Typical circuit configuration, NFPA Style Y:

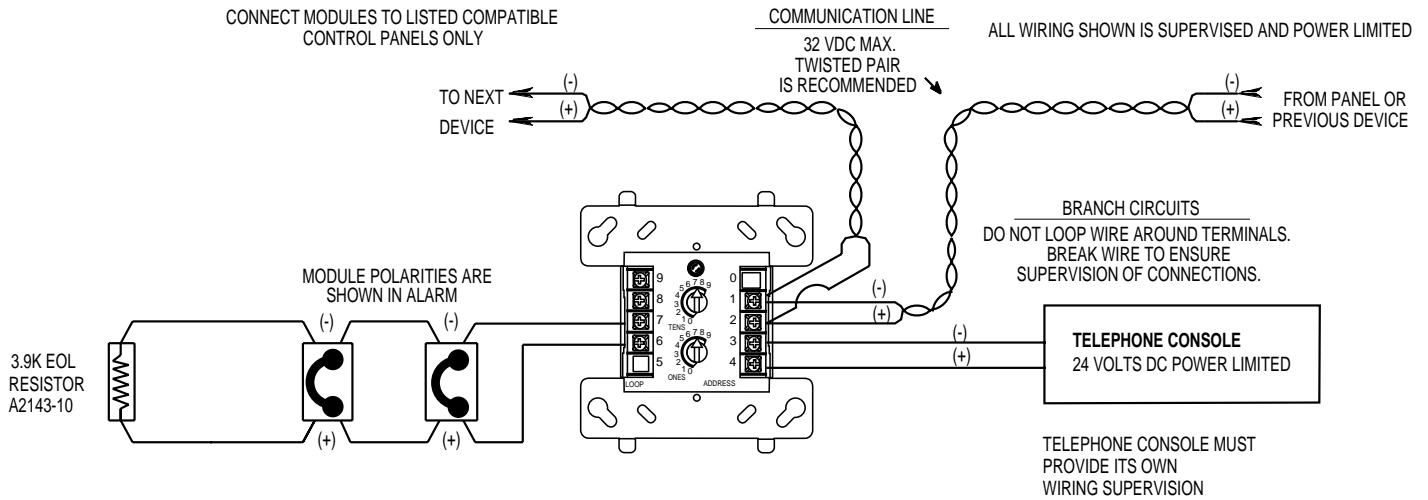

A78-2282-27

Figure 4. Typical fault tolerant circuit configuration, NFPA Style Z:

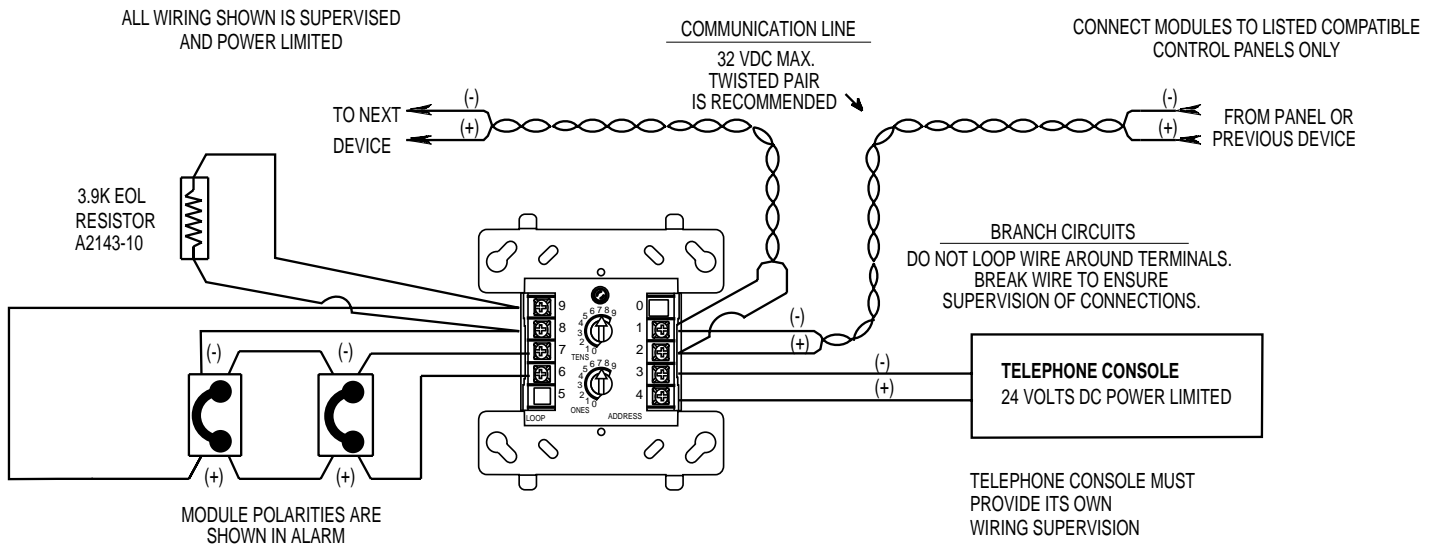

A78-2283-16

Relay Contact Rating: 3 Amperes maximum

WARNING

All relay switch contacts are shipped in the standby state (open) state, but may have transferred to the activated (closed) state during shipping. To ensure that the switch contacts are in their correct state, modules must be made to communicate with the panel before connecting circuits controlled by the module.

FCC Statement

This equipment has been tested and found to comply with the limits for a Class B digital device, pursuant to Part 15 of the FCC rules. These limits are designed to provide reasonable protection against harmful interference. This equipment generates, uses, and can radiate radio frequency energy and, if not installed and used in accordance with the instruction manual, may cause harmful interference to radio communications. Operation is subject to the following two conditions: (1) This device may not cause harmful radiation, and (2) this device must accept any interference received, including interference that may cause undesired operation.