

500 Series™ Intelligent Duct Smoke Detector

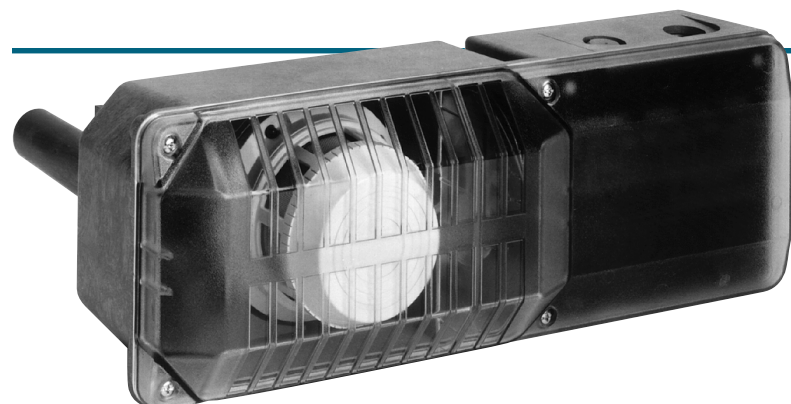

A Division of Pittway
3825 Ohio Avenue, St. Charles, IL 60174
1-800-SENSOR2 (736-7672), Fax 630-377-6495
<http://www.systemsensor.com>



Models Available

DH500 Duct Smoke Sensor Housing
**DH500ACDC Duct Smoke Sensor Housing with
Optional Fan Control**

Features

- DH500
 - Operates from the control panel communication line
 - Has outputs for remote LED output, remote test (24 VDC)
- DH500ACDC
 - 24 VAC/DC or 120/220 VAC operation
 - Powered outputs for remote LED, remote test and sounder
 - Two Form C auxiliary contacts
(external supply is required only when using the auxiliary relay or connecting any accessories)
- Continuous sensitivity monitoring from the panel
- Intelligent ion or photo heads with twist-in/twist-out removal
- Air velocity rating from 500 to 4000 fpm
- Remote test station and remote annunciator accessories
- Clear polycarbonate cover for convenient visual inspection of sampling tube filters
- UL 268A listed
- 3-year warranty

Specifications – DH500

Voltage Range:	15 – 28 VDC peak	Operating Temperature Range:	32° to 120° F (0° to 49° C)
Standby Current (nominal):	200 μ A at 24 VDC	Operating Humidity Range:	10% to 93% relative humidity
Power-up Surge at Max. Rated Voltage:	1.5 mA/sec.	Duct Air Velocity:	500 – 4000 ft./min. (91.4 – 1219.2 m/min.)
LED Current (nominal):	6 mA at 24 VDC		
Length:	14.5 inches (36.7 cm)		
Width:	5 inches (12.7 cm)		
Depth:	4 inches (10.2 cm)		
Weight:	4 lbs. (1.8 kg)		



MEA
approved

General Description

System Sensor premium duct detectors, Models DH500 and DH500ACDC, feature the superior capabilities of an intelligent sensor in a unit that is easy to install and maintain. The DH500 Series Duct Housing samples air currents passing through a duct and gives dependable performance for shutdown of fans, blowers, and air conditioning systems, preventing the spread of toxic smoke and fire gases through the protected area.

Both Model DH500 and DH500ACDC duct housings can accommodate either the 1551B Intelligent Ionization Sensor or the 2551B Intelligent Photoelectronic Sensor. The twist-in, twist-out heads allow for quick and easy cleaning or application changes without removing the duct housing.

These sensors communicate and are continuously monitored through the communication line. Detector sensitivity changes caused by dirt, smoke, temperature, or humidity are reported to the panel, allowing compensation algorithms to maintain the sensor's set sensitivity. An advance indication at the panel specifies the sensor

address, allowing for selected maintenance to be performed as needed.

Remote alarm annunciation can be accomplished by using the RA400Z Remote Annunciator or the RTS451 or RTS451KEY Remote Test Station. The RTS451 and RTS451KEY allow testing of the detector from a remote location. The detector must be reset from the control panel. Model DH500 incorporates zener diodes to conserve power for communications to other devices and limit power to supplementary accessories at times of high power demands.

WARNING: Duct smoke detectors have specific limitations. **DUCT DETECTORS ARE**

- NOT** a substitute for an open area smoke detector,
- NOT** a substitute for early warning detection, and
- NOT** a replacement for a building's regular fire detection system.

Refer to NFPA 72 and 90A for additional duct detector application information.

Architect/Engineer Specifications

The air duct smoke detector shall be a System Sensor Model DH500ACDC or DH500 Intelligent Series Smoke Duct Detector to be used with compatible control units. The detector housing shall be UL listed per UL 268A specifically for use in air handling systems. The detector shall operate in air velocities from 500 to 4000 feet per minute. The detector housing shall be equipped with an integral mounting base capable of accommodating either intelligent photoelectronic or intelligent ionization detector heads. It shall be capable of local testing via magnetic switch or remote testing from the RTS451 or RTS451KEY Remote Test Station. The duct detector housing shall

incorporate an airtight smoke chamber in compliance with UL 268A, Standard for Smoke Detectors for Duct Applications. The housing shall be capable of mounting to either rectangular or round ducts without adapter brackets. An integral filter system shall be included to reduce dust and residue effects on detector and housing, thereby reducing maintenance and servicing. Sampling tubes shall be easily installed after the housing is mounted to the duct by passing through the duct housing. Terminal connections shall be of the strip and clamp method suitable for 14-18 AWG wiring. Wiring shall be connected to a terminal strip and be so noted.

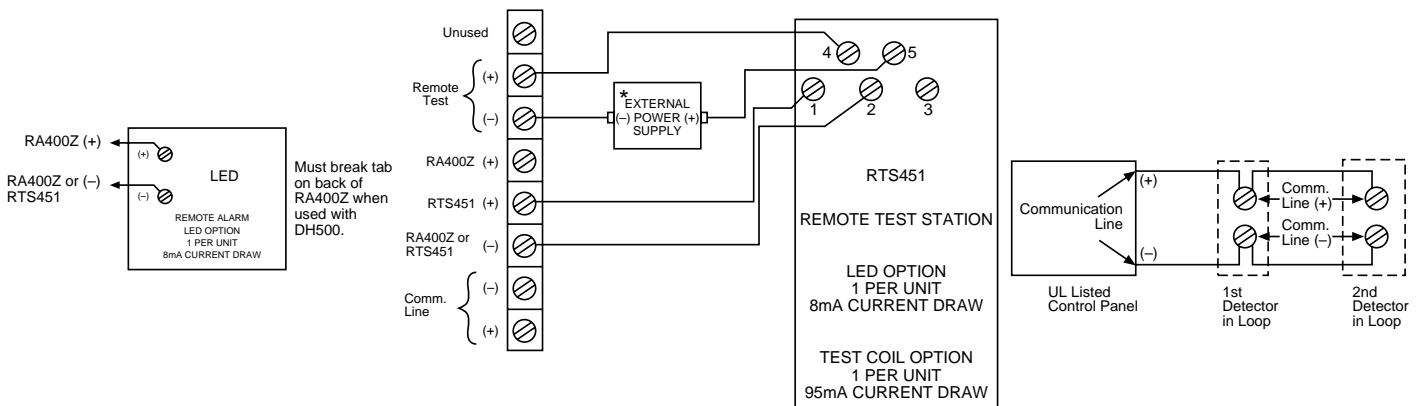

System Wiring Diagram for DH500 Duct Smoke Detector Using a UL Listed Control Panel

DH500ACDC Power Supply Electrical Ratings

Power Requirements	120 VAC (120 – 132)		240 VAC (204–264)		24 VAC (20.6–26.4)		24 VDC (20–30)	
	mA rms maximum		mA rms maximum		mA rms maximum		ma DC maximum	
Device	Standby	Alarm	Standby	Alarm	Standby	Alarm	Standby	Alarm
DH500ACDC	44	52	25	30	65	182	26	87
PA400*	—	3	—	1.5	—	29	—	15
RA400Z*	—	1.5	—	1	—	17.3	—	7
RTS451*	—	1.5	—	1	—	17.3	—	7
RTS451**	11.5	13	5.5	6.5	140	157	71	78
RTS451KEY**	11.5	13	5.5	6.5	140	157	71	78

The currents shown for the DH500ACDC are maximum values with no accessories.

*All accessory currents are additional to DH500ACDC. There are no additional currents for accessories in standby.

**These devices draw current when the magnet is held in place to initiate an alarm.

Auxiliary Relay Contacts

10 amps maximum at 30 VDC; 10 amps maximum at 277 VAC.

1/3 Hp at 240 VAC; 360 VA at 240 VAC.

Programming Specifications

Additional requirements for intelligent system control panels:

1. The panel must not continuously poll the same unit for more than 3 seconds or the auxiliary relay and auxiliary alarm output could switch states. After 3 seconds of continual polling of a device, the panel must wait a minimum of 100mS before polling or communicating to that same device.
2. Communications must not cease for more than 3 seconds without an additional clock pulse (after Pulse Width 5) to turn off the LED on the sensor.
3. To allow the auxiliary relay and auxiliary alarm output to return to a standby condition, (after being in alarm) the panel must wait a minimum of 100mS after turning off the sensor LED before re-communicating to the same device.

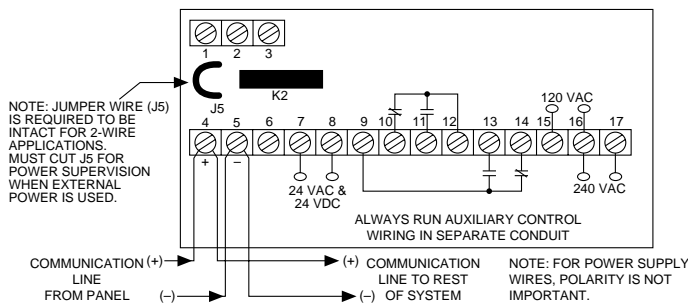

System Wiring for DH500ACDC

24v auxiliary output maximum load is 80 mA;
alarm output maximum load is 20 mA.

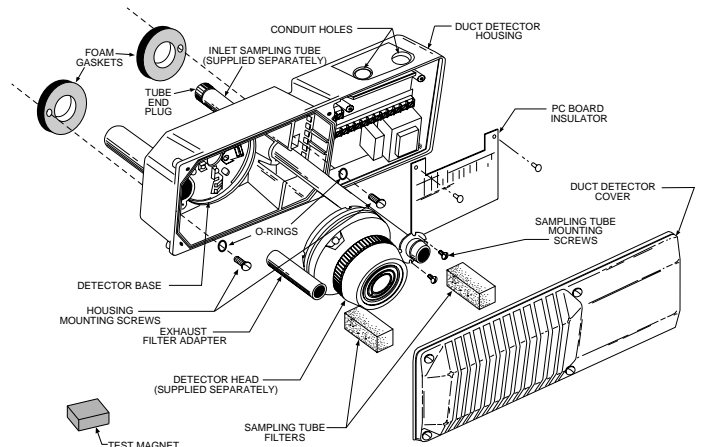
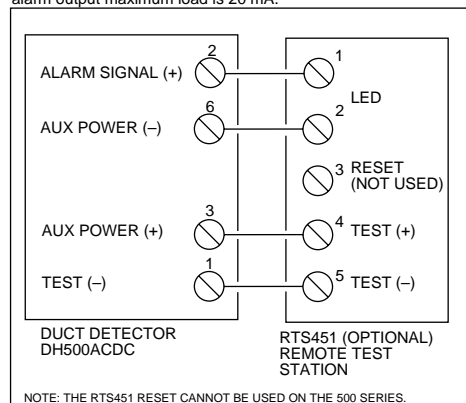

Exploded View of DH500ACDC Duct Smoke Detector Components

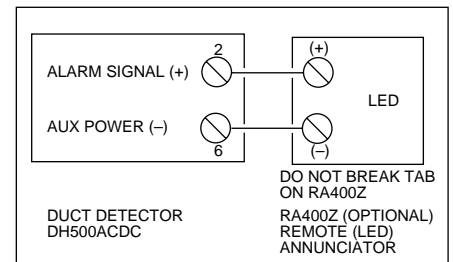
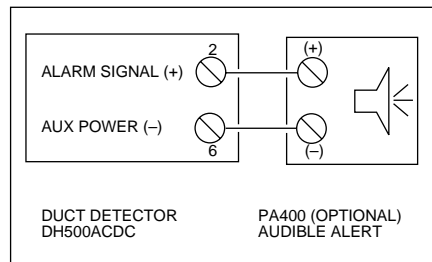

Accessory Wiring

Ordering Information

Part No.	Description	Accessories
DH500ACDC	Intelligent duct smoke sensor housing with auxiliary relays	RTS451 Remote test station (see below)
DH500	Intelligent duct smoke sensor housing	RTS451KEY Remote test station with key (see below)
1551B	Intelligent ionization sensor head	RA400Z Remote LED (see below)
2551B	Intelligent photoelectronic sensor head	PA400 Piezo alert sounder (see below)
ST-1.5	Metal sampling tube duct widths 1'-2'	F36-05-00 Replacement filters
ST-3	Metal sampling tube duct widths 2'-4'	M02-04-00 Test magnet
ST-5	Metal sampling tube duct widths 4'-8'	P48-21-00 End cap for sampling tube
ST-10	Metal sampling tube duct widths 8'-10'	A2650-01 Installation kit (parts bag)
		RS24 Photoelectronic replacement screen
		RS14 Ionization replacement screen
		MOD400R Sensitivity test kit
		CRT400 Ionization cover removal tool

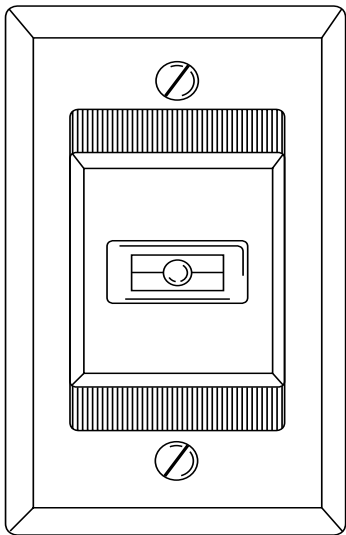

RA400Z
Remote LED



PA400
Piezo Alert Sounder



RTS451
Remote Test Station

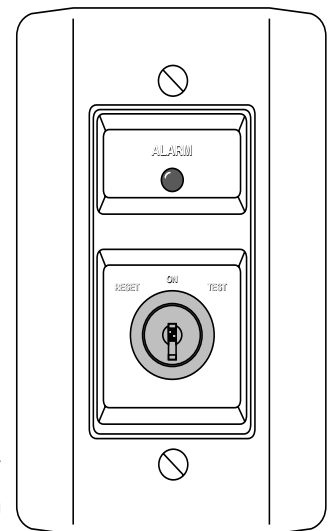

RTS451KEY
Remote Test Station

System Sensor Worldwide Manufacturing & Distribution

In Canada:

System Sensor Canada, A Division
of Pittway Corporation of Canada
6581 Kitimat Road, Unit #7
Mississauga, Ontario
Canada L5N 3T5
Telephone: 905-812-0767
Fax: 905-812-0771

In the United Kingdom:

System Sensor Europe, Ltd.
A Member of Pittway Corporation
Horsham Gates III, North St.
Horsham, West Sussex
RH13 5PJ, United Kingdom
Telephone: 44-1403-276500
Fax: 44-1403-276501

In India:

System Sensor India
A Division of Pittway
A-204 Maheshwari Nagar
Orkay Mills Lane
Andheri East, Mumbai 400093
Telefax: 91-022-8202564

In the Far East:

System Sensor Far East
A Division of Pittway
Rm 903, Tower A, New Mandarin
Plaza, 14 Science Museum Road
TST East, Kowloon, Hong Kong
Telephone: 852-2191-9003
Fax: 852-2736-6580