

MODEL 6200 OPTICAL BEAM SMOKE DETECTOR

ADDRESS CODING		DIGIT REQUIRED	Switch "8"	Switch "4"	Switch "2"	Switch "1"
SW10	ON	0	off	off	off	off
	1	1	off	off	off	on
	2	2	off	off	on	off
	4	3	off	off	on	on
	8	4	off	on	off	off
	1	5	off	on	off	on
	2	6	off	on	on	off
	4	7	off	on	on	on
TENS	8	8	on	off	off	off
	8	9	on	off	off	on

TABLE 1 - SETTING THE DEVICE ADDRESS ON A 6200

Switch setting					Chosen sensitivity level	Relative sensitivity
SW5	SW4	SW3	SW2	SW1		Most sensitive = 1
off	off	off	off	on	maximum	1
off	off	off	on	off		1.3
off	off	on	off	off	medium	1.6
off	on	off	off	off		2.0
on	off	off	off	off	minimum	2.5
any other					Default (minimum)	2.5

TABLE 2 - SENSITIVITY ADJUSTMENT
CAUTION

Fire detection system components must be installed in accordance with the manufacturers stated operating parameters and with applicable recognised international and national standards or local codes of practice. Design, installation, commissioning and maintenance should be undertaken by competent organisations. Service should be undertaken on a regular basis in line with accepted codes of practice. Detection may not be effective if local conditions change or if equipment is not properly maintained. System sensor warrants this product to be free of manufacturing defects or component failure for three years from original supply but accepts no responsibility for claims of consequential loss as a result of such failures or defects. Defective product will be repaired or replaced when returned via the original distributor.

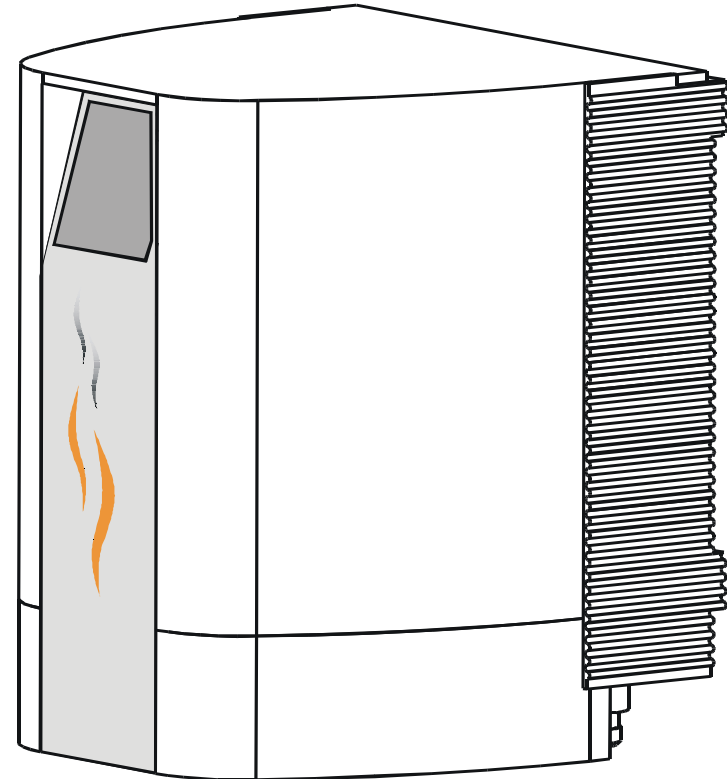

**MODEL 6200
ANALOGUE ADDRESSABLE
OPTICAL BEAM SMOKE DETECTOR**

REFERENCES AND DESIGNATIONS

Reference	Description
6200	Analogue Addressable Intelligent linear beam detector
6200R	Conventional linear beam detector with dry relay contact
REFL20	Short to medium range reflector
REFL30	Medium range reflector
REFL50	Medium to long range reflector
6200-BR	Remote unit for 6200 (refer to Accessory Data sheet)
6200-OBK	Orientation bracket kit (refer to Accessory Data sheet)
6200-C	Heating pad kit (refer to Accessory Data sheet)
REFL20-C	REFL20 Heating pad kit (refer to Accessory Data sheet)
REFL30-C	REFL30 Heating pad kit (refer to Accessory Data sheet)
REFL50-C	REFL50 Heating pad kit (refer to Accessory Data sheet)
6200 FILTER	Filter for alarm test

GENERAL

The 6200 is a reflector-type Linear Optical Beam smoke detector designed to operate as a component of an intelligent analogue addressable fire detection system, powered directly from the loop itself. The detector operates primarily on the principle of light obscuration, i.e. the alarm is triggered as a result of the change in the optical transmission of a beam of light beyond a set threshold.

The beam is designed to comply with the requirements of the draft European standard prEN54-12 (1998 edition) and is third party tested and approved to that standard.

The detector comprises two parts:

1. A unit containing all the electronics associated with the detector: Light Beam Emitter, Receiver, Signal Processing, and System Communication.
2. A high-efficiency reflector, which returns the light beam emitted.

INSTALLATION RECOMMENDATIONS

Installation should be undertaken in accordance with recognised international standards or required codes of practice. See the System Sensor "Guide for Proper Use of Projected Beam Smoke Detectors", reference I56-506, for installation guidelines. The following recommendations should also be taken into account:

Height of premises (H)	Distance of beam to ceiling (D)	Area of effective detection (width from beam centre)
$2.5 \text{ m} \leq H \leq 5 \text{ m}$	$0.3 \leq D \leq 0.5 \text{ m}$	5 m
$5 \text{ m} \leq H \leq 12 \text{ m}$	$0.5 \leq D \leq 2 \text{ m}$	7 m

Note : We recommend that simulated fire tests should be conducted to ensure that an adequate speed of response is achieved with the detector spacing utilised on each specific installation.

When designing the location and layout of the detectors, the following factors must be taken into account:

1. No obstruction should obscure the beam. The beam is narrow, but can move across the reflector. Make sure a cone of view is clear for the beam from the 6200, the base of which is at least equal to the overall dimension of the reflector.
2. Do not place the beam in a location where it may be interrupted by site activity (conveyor belts, fork lift trucks etc.), which can cause unwanted alarms and fault conditions.
3. Ensure the led indicators are clearly visible, unless a remote indicator or repeater unit has been provided.
4. Ensure freedom of access to the detector for installation and maintenance operations.
5. Do not expose the detector or its reflector to radiated light from other beams, or other intense sources of light.
6. It is critical that the transmitter/receiver part of the detector be installed on a rigid support, to prevent unwanted alarms and faults being triggered by structural movement of the building. The size of the reflector must be chosen in relation to the possible movement of the 6200 (see the curves on page 7 of this document). The reflector is not subject to the same restrictions.
7. Centre the red spot (visible when unit is switched to "installation" mode) emitted by the beam onto the reflector in order to provide for maximum tolerance to any structural movement of the building.
8. Install the 6200 onto an even vertical surface, which avoids any possible twisting of the termination box. Uneven mounting surfaces can create problems. If necessary, use an intermediate plate, or the optional mounting bracket (6200-OBK).
9. Use round headed screws (not countersunk), $\phi 3.5 \text{ mm}$, to mount the termination box. The 6200 is light, so avoid excessive screw tightening which might stress the plastic termination box.

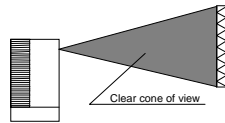

ELECTRICAL SPECIFICATIONS

PARAMETERS	6200
Power supply	Via intelligent loop (15 to 28 Vdc)
Power consumption in standby	3.2 mA at 20V
Power consumption in alarm mode	12 mA at 20V
Power consumption in fault mode	12 mA at 20V
Power consumption in contamination mode	12 mA at 20V
Power consumption in installation mode	< 40 mA at 20V Note: Set only one unit per loop to this mode simultaneously

MECHANICAL SPECIFICATIONS

PARAMETERS	6200	REFLEX 20	REFLEX 30	REFLEX 50
Weight	1 kg	0.5 kg	1 kg	3.5 kg
Overall dimensions (mm)	195(h) x 155(l) x 150(w)	205(h) x 205(l) x 30(w)	305(h) x 305(l) x 30(w)	548(h) x 508(l) x 20(w)
Protection number	IP41	-	-	-
Material	ABS	Aluminium	Aluminium	Aluminium
Colour	Grey, eggshell finish	Grey	Grey	Grey
Mounting	Screws at housing fixing points indicated	Screw fixing lugs	Screw fixing lugs	Screw fixing lugs
Cable termination	Via 5 knock-outs with appropriate cable glands	-	-	-

CLIMATIC SPECIFICATIONS

PARAMETERS	6200
Temperature	
• Operating	-10 to +55°C
• Storage	-20 to +70°C
Admissible relative humidity	
• Operating	< 95% non-condensing
• Storage	< 95% non-condensing

OPTICAL SPECIFICATIONS

PARAMETERS	6200	REFLEX 20 (*)	REFLEX 30	REFLEX 50
Range	10 to 100 m	10 to 30 m	30 to 50 m	30 to 100 m
Wavelength	670 nm (red)	-	-	-
Horizontal/Vertical adjustment	$\pm 10^\circ$ by 2 screws	none	None	none
Allowable movement during normal operation	Refer to table below (*)	$\pm 15^\circ$	$\pm 15^\circ$	$\pm 15^\circ$

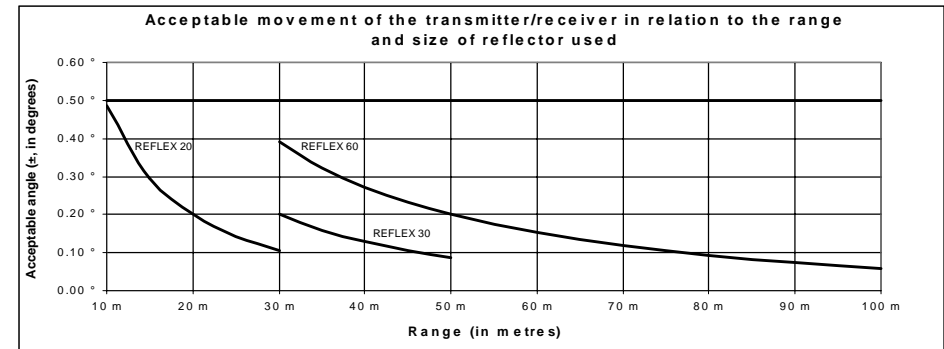

(*) The admissible movement of the beam depends on the range and the surface area of the reflectors.

FUNCTIONAL TESTS

To test the fault condition

Completely obstruct the beam between the transmitter and reflector with a non-reflective material, such as a sheet of cardboard, for example. After approximately 20 seconds:

1. The yellow fault LED should light
2. A fault condition should be signalled to the control panel

Clear the obstruction from the beam path. After a few seconds:

1. The yellow fault LED should go out
2. The device returns to standby on the indicator panel

To test the alarm condition

Obstruct the beam at or close to the transmitter/receiver unit, using the appropriate "ALARM" end of the filter supplied (6200 FILTER). Insert the filter into the path of the beam at an oblique angle (not perpendicular to the beam path) otherwise it may act as a reflector instead of an obscuration filter. After approximately 20 seconds:

1. The red alarm led should light
2. An alarm condition should be signalled to the control panel

Remove the filter from the beam path, then reset at the control panel. After a few seconds:

1. The red alarm LED should go out
2. The device returns to standby on the indicator panel

Obstruct the beam again, this time using the end of the filter marked "NO ALARM", checking that the beam and panel do not signal an alarm.

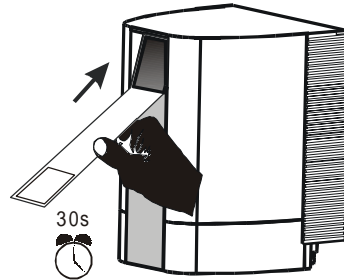

BEAM TEST FILTER

OPERATION

Standby condition

This is the normal status for the detector. No LED indicators should be lit.

Alarm condition

The red alarm LED (under the 6200) is lit continuously. The alarm LED will remain lit until the unit is reset under command from the control panel.

On the control panel, the relevant visual and audible indicators will operate (see the instructions for the control panel):

1. Acknowledge the alarm signal
2. Follow the fire instructions
3. When the cause of the alarm has been investigated and resolved, reset the control panel, which resets the detector (and switches off the red LED).

Fault condition

The cause of a fault may be due to:

1. **Obstruction / mis-alignment of the beam:** In this case, the yellow fault LED is turned on steady. To return to standby status remove the obstruction or re-align to ensure the path of the beam remains clear to the reflector.
2. **Incorrect start-up or detector failure:** This fault occurs immediately after exiting the installation mode. The yellow fault LED illuminates continuously. The installation procedure should be repeated and all parameters checked for this fault to be cancelled.
3. **Excessive contamination of the optical parts:** The yellow fault led flashes. The 6200 is capable of compensating the signal for contamination up to a preset limit. Carefully wipe the beam window and the reflector surface clean with a damp cloth then revert to installation mode to check signal strength and beam alignment. The detector should then return to standby.

On the control and indicating panel, the relevant visual and audible warnings are triggered.

1. Acknowledge the warning signals
2. Go to the zone related to the fault condition and identify the possible cause
3. Inform service personnel, and follow the agreed safety procedures for the installation.

REFLEX 20 and 30

REFLEX 20: L = 180
REFLEX 30: L = 281

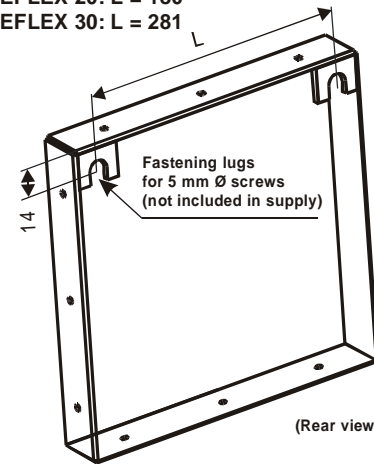

(Rear view)

N.B.: Provision is made to connect several reflectors together if required

REFLEX 50

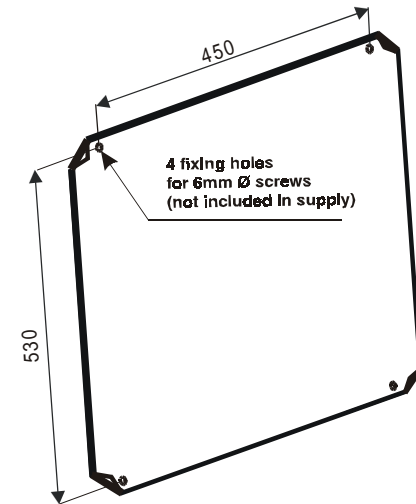

INSTALLATION MOUNTING LIMITS

Internal adjustment of the optical assembly within the 6200 housing allows the beam to be installed on flat surfaces, inclined up to 10° from the required beam path. Similarly the reflector can accommodate an offset of up to 15° from the beam path. If the angle is greater than those indicated, use the 6200-OBK orientation bracket kit for improved alignment.

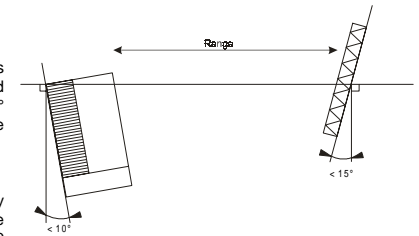

ALIGNMENT RECOMMENDATIONS

The model 6200 offers significant set-up advantages by providing easy alignment when using the "installation" mode, which generates a visible targeting spot of light. However when setting up at distances greater than 50 meters:

1. Try to choose the time of installation when the (natural) lighting in the premises is reduced to emphasise spot intensity
2. Use structural elements (ceilings, girders, partitions etc.) to identify the trajectory of the beam. If necessary, use a large-dimension back-up reflector surface to aid the alignment with the final installed reflector.

EXAMPLE

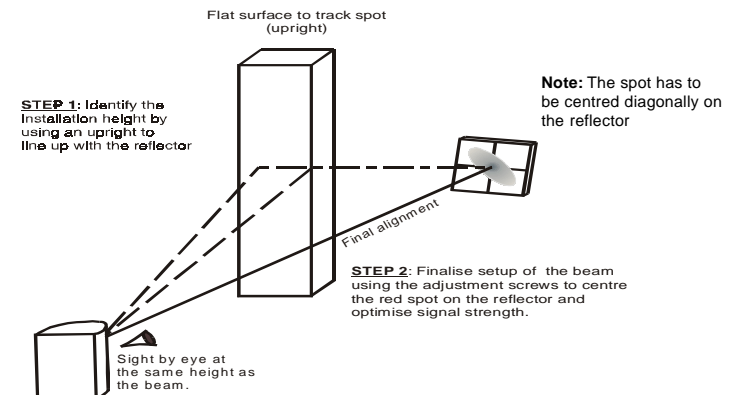



INSTALLATION

It is recommended to use the following steps for set-up:

- A. Disassemble the beam as shown
- B. Mount securely to a fixed vertical surface
- C. Connect field wiring and assemble optical module
- D. Set the switch configuration as required
- E. Connect system loop wiring to panel and apply power
- F. Engineers switch - set to "installation" position
- G. Align beam and centre on reflector
- H. Assemble housing cover
- I. Engineers switch - set to "operating" position
- J. Close the bottom access door



Alarm conditions may be generated during the set-up phase thus the control panel should be switched to engineering mode with outputs isolated until beam detector commissioning has been completed.

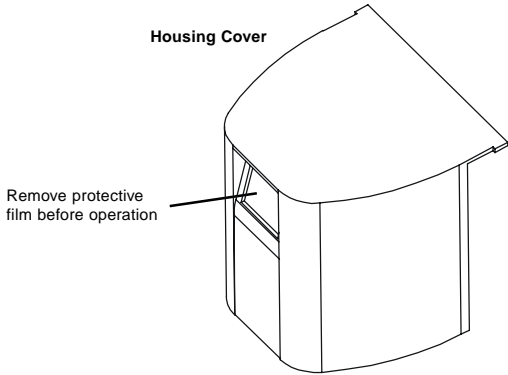

D. SWITCH CONFIGURATION

Standard (sensitivity) settings recommended

Level 1 or 2, the fastest detection, and the most sensitive, for areas subject to rapid air movement

Level 4 or 5, the least sensitive, and the slowest response, for areas with higher contamination (e.g. dust, condensation), or long beam lengths (<70m)

Do not select several switches at once otherwise minimum sensitivity is adopted by default; refer to TABLE 2

Set the unit address

The address is set in the range 01-99 according to the coding scheme indicated in TABLE 1 and inside the 6200 housing cover.

E. CONNECT TO PANEL AND APPLY POWER

A. DISASSEMBLE MAJOR COMPONENTS

Remove housing cover by releasing captive screws (shown X), then carefully separate optical assembly from rear termination box after releasing captive screws (shown Y) and disconnecting plugs from sockets marked J1, J2 and B1 on the termination PCB.

B. FIX TO VERTICAL SURFACE

Maintain minimum clearance distances around beam as indicated in diagram above. Ensure termination back box is fixed securely to a rigid vertical surface directly opposite to the mounted reflector. Do not distort the box moulding by over-tightening fixing screws. (Note: an adjustable mounting bracket is available if required as a special order accessory).

C. CONNECT FIELD WIRING AND REFIT OPTICAL MODULE

Terminate cables through knock-outs provided in bottom plate (use glands provided or compatible alternatives)

Connect to terminals in accordance with details shown.

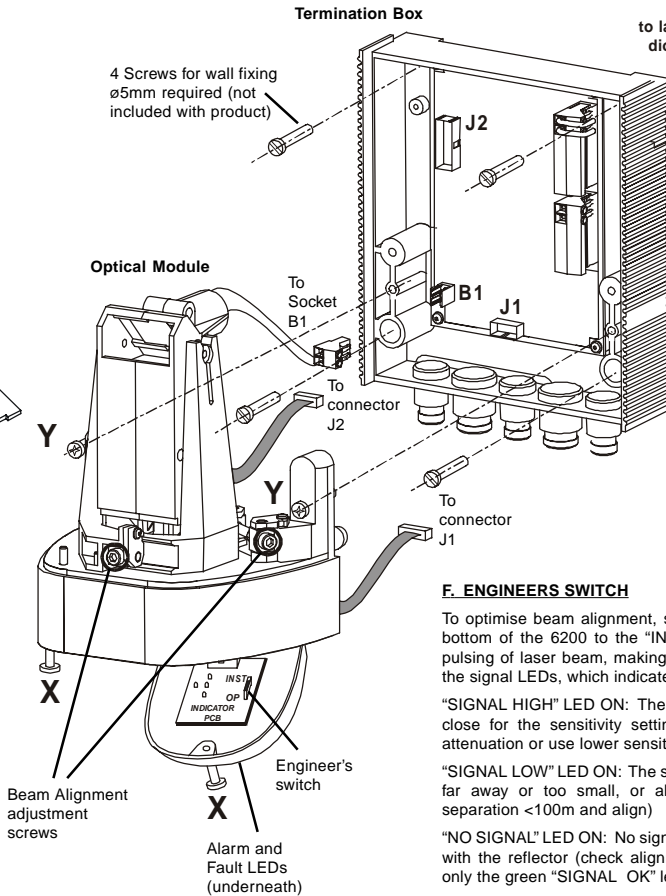

F. ENGINEERS SWITCH

To optimise beam alignment, set switch SW1 on the Indicator PCB at the bottom of the 6200 to the "INSTALLATION" position. This provides rapid pulsing of laser beam, making visible adjustment easy, in conjunction with the signal LEDs, which indicate the following:

"SIGNAL HIGH" LED ON: The signal is saturated; the reflector must be too close for the sensitivity setting (fit cover onto beam as it adds a little attenuation or use lower sensitivity setting)

"SIGNAL LOW" LED ON: The signal received is too weak, the reflector is too far away or too small, or alignment is not correctly adjusted (ensure separation <100m and align)

"NO SIGNAL" LED ON: No signal detected, the beam is not correctly aligned with the reflector (check alignment). When the beam is aligned correctly only the green "SIGNAL OK" led should be on.

G. BEAM ALIGNMENT AND CENTERING ONTO REFLECTOR

Accurate adjustment of the beam may be made in both the vertical and horizontal planes by use of the two adjustment screws indicated (use hex Allen key/wrench no.8). Ensure the focus of the beam is central on the reflector.

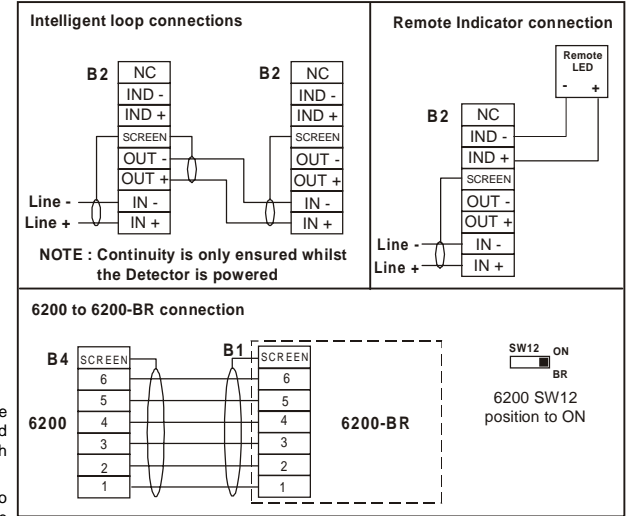
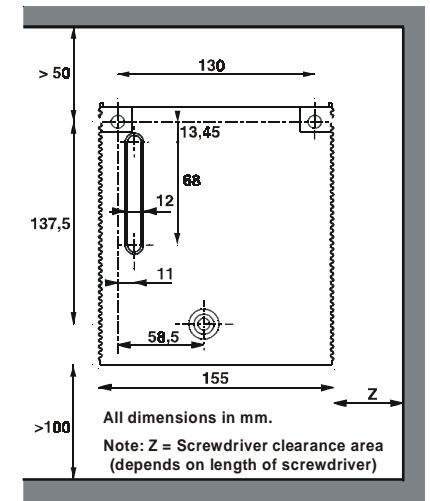
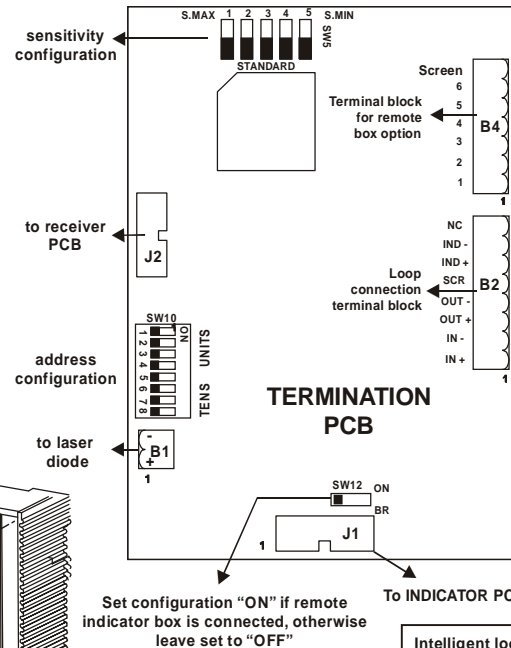

H. COVER INSTALLATION

Replace the housing cover, attaching it using the relevant captive screw marked X.

I. ENGINEERS SWITCH - NORMAL OPERATION

Only return the Indicator PCB switch SW1 to the "operating" position when the cover is correctly refitted. The green led should light up for a few seconds (do not disturb the beam during this time). All indicators should be off in the normal monitoring state.

J. CLOSE THE BOTTOM ACCESS DOOR

Close the lower Indicator PCB door and fix using the captive screw marked X.

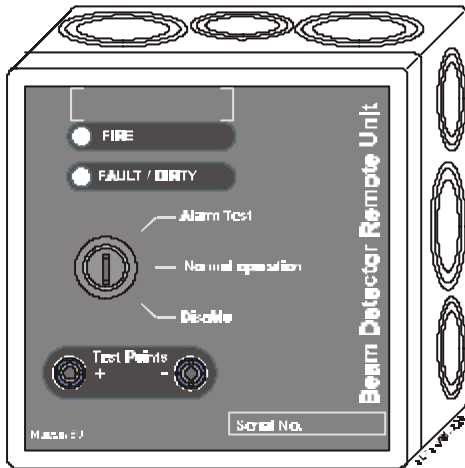

GENERAL DESCRIPTION

6200BR is a Remote Annunciator and Control unit for the 6200 range of reflector type linear optical beam smoke detectors permitting easier operation and maintenance of the detector. It is particularly recommended for use in installations where access to the detector is restricted, or if the detector is out of sight.

The 6200BR offers the following features:

- LED Indication of a Fire Alarm.
- LED Indication of Faults.
- Test points permit monitoring of dirt build up or condensation on the optical parts within the detector hence enabling easy scheduling of maintenance.
- Alarm Test (key on "Test Alarm" position).
- Detector Disabled (key on "Disable").
- Detector Reset (key from "Disable" to "Normal")
- Dry contacts (normally closed or normally open) that indicate the Detector is disabled.

WARNING

One 6200BR should be fitted for each detector to be monitored. The 6200BR must not be connected to more than one detector.

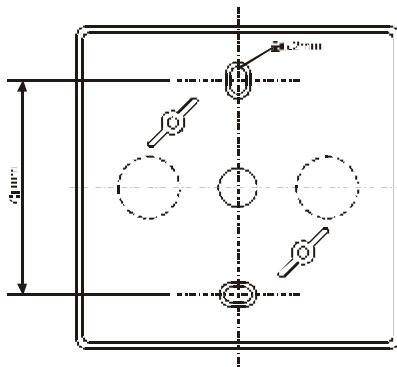

WALL MOUNTING

2 x Ø 3 mm screws (not included)

Installation height: 1,3 to 1,5 m

The 6200BR uses similar mountings to standard electrical back boxes, giving flexibility in mounting the Remote Annunciator and Control unit and allowing the unit to be mounted unobtrusively.

Easy access to the 6200BR enables all personnel to ascertain the status of the Detector enabling appropriate action to be taken.

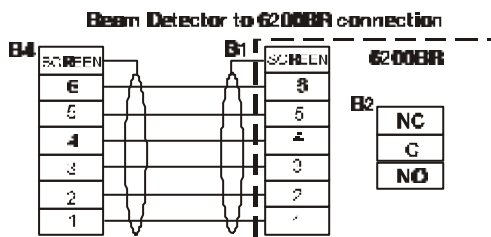

WIRING CONNECTIONS

DETECTOR CONNECTION: B1

PIN	Function
1	0 V (line -)
2	Fire Alarm lamp control
3	Fault/Dirty lamp control
4	Test point
5	Alarm test
6	Detector disabling
7	Screen

DRY CONTACTS CONNECTOR: B2

PIN	Label	Function
1	NO	Normally open contact
2	C	Common
3	NC	Normally closed contact

**KEY SWITCH**

The key switch has three positions that permit testing or disablement of the Alarm during routine maintenance:

NORMAL OPERATION.

Normal position of the key switch, allowing normal fire detection system operation

ALARM TEST.

Tests the operation of the detector's optical parts and electronics. The test simulates fire conditions and gives reasonable assurance that the Beam Detector is operating correctly.

DETECTOR DISABLED.

Disables the detector if the beam is going to be obstructed. Whilst the detector is disabled, a fault signal is sent to the panel. The yellow LEDs on both the detector and the remote box will be continuously lit whilst the detector is disabled.

Briefly turning the key to this position will also reset the 6200R following an alarm or alarm test.

Note: The Control Panel resets Alarms on the 6200

The Key can only be removed in the "Normal Operation" position.

Note: All 6200BR keys are the same**OPERATION****STANDBY CONDITION**

No LED's lit and the key is on "Normal Operation"

YELLOW LED ILLUMINATED

If the key is set to "Normal operation": then the Detector is in fault status.

The yellow LED is turned on continuously when an obstruction to the detector beam or detector failure occurs.

FLASHING YELLOW LED

Indicates excessive contamination of detector optical parts.

If the key is set to "Disable" then the Detector is disabled.

Once the fault is cleared, the yellow LED will automatically turn off.

RED LED ILLUMINATED

If the key is in the "Normal Operation" Position, the detector is in alarm.

If the key in the "Alarm test" position, the detector is in alarm test.

Following an alarm, or an alarm test, it is necessary to reset the detector either from the control panel (6200) or by briefly switching from the "Normal" to the "Disable" position (6200R).

Note: The Control Panel controls the illumination of the RED LED (6200)**SPECIFICATIONS****MECHANICAL SPECIFICATIONS**

PARAMETERS	
Weight	200 g
Overall dimensions	108(H)x108(L)x57(W) mm
Protection index	IP55-5
Colour	Cool grey RAL7035, blue, yellow
Mounting	2 x Ø3mm Screws
Roof fixing	Clips
Cable termination	12 knock-outs

ENVIRONMENTAL SPECIFICATIONS

PARAMETERS	
Temperature Operating Storage	- 10 to + 55°C + 10 to + 50 °C
Admissible relative humidity Operating Storage	< 95 % without condensation < 85 % without condensation

ELECTRICAL SPECIFICATIONS

Power for the 6200BR is derived from the detector; maximum cable length 100 m.

Note: The use of a 6200BR does not increase the power consumption of the detector.

TEST POINTS

Two 4mm diameter test connectors provide a DC voltage relating to the light power received by the photodiode. These test points must only be used for the connection of a suitable meter capable of reading up to 12VDC. (Red positive, Black negative)

DETECTOR STATUS

Detector status is reported by 2 LEDs:

A red LED indicates Alarm: In alarm, this LED will be illuminated until the detector is reset.

A yellow led indicates a fault: In fault this is continuously lit when an obstruction to the detector beam occurs, and flashes to indicate a dirty Optical Chamber

DRY CONTACTS OUPUTS

Normally open and normally closed contacts are used to signal alarm disabled.

INSTALLATION MANUAL FOR HEATING ELEMENTS 6200-C, REFL-C AND REFL50-C



6200-C Heater Kit

Mounted on 6200 Emitter Receiver

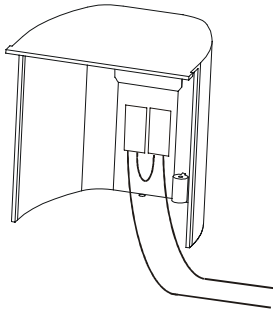

Mounting:	The 6200-C Heating Kit should be mounted on the interior of the cover as shown, without obscuring the window.
Power Supply:	24VAC or 24VDC +/- 4VDC, 170mA
Wiring:	Two 12V elements wired in series
Size:	Each element 50mm x 25mm
Adhesive:	3M966

REFL-C Heater Kit

Mounted on REFL20 or REFL30 Reflectors

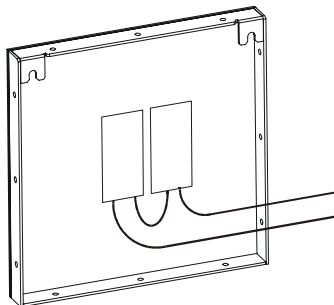

Mounting:	The REFL-C Heating Kit should be mounted on the rear of the reflector, in the centre of the area as shown
Power Supply:	24VAC or 24VDC +/- 4VDC, 700mA
Wiring:	Two 12V elements wired in series
Size:	Each element 50mm x 100mm
Adhesive:	3M966

REFL50-C Heater Kit

Mounted on REFL50 Reflector

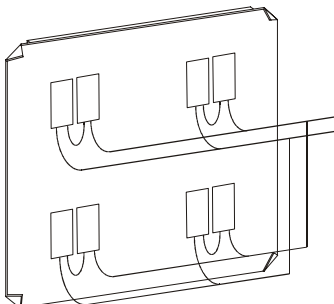

Mounting:	A pair of heating elements should be mounted in the centre of each quarter of the reflector.
Power Supply	24VAC or 24VDC +/- 4VDC, 2.8A
Wiring:	Eight 12V elements wired as pairs in series, then in parallel.
Size:	Each Element 50mm x 100mm
Adhesive:	3M966

INSTALLATION

- 1 Clean the surface on the detector or reflector where the heating elements are to be positioned (see diagrams above).
- 2 Remove the protective sheet on the self adhesive pads
- 3 Position the heating elements and press them firmly into place over the whole of the heater surface to ensure good thermal contact is made.
- 4 Connect the two elements in series to a suitable 24VAC or 24VDC power supply. Do not mix different heating elements series together. Power supply current rating must be a minimum of $(170 \times n + 700 \times m)$ mA where n is the number of detector heating kits and m the number of reflector kits.

RECOMMENDATIONS

- 1 Do not bend, cut or scratch the heating elements
- 2 If a heating element has been incorrectly positioned, it is possible to **carefully** un-stick and reposition it. However this operation may reduce the effectiveness of the adhesive pad, therefore it is advised to add a thin layer of silicon adhesive.
3. Do not connect two different sized heating elements in series.

6200-OBK ORIENTATION KIT INSTALLATION INSTRUCTIONS



BEAM DETECTOR MOUNTING ONTO 6200-OBK ORIENTATION KIT

Pivot Bracket
See below for
mounting details.

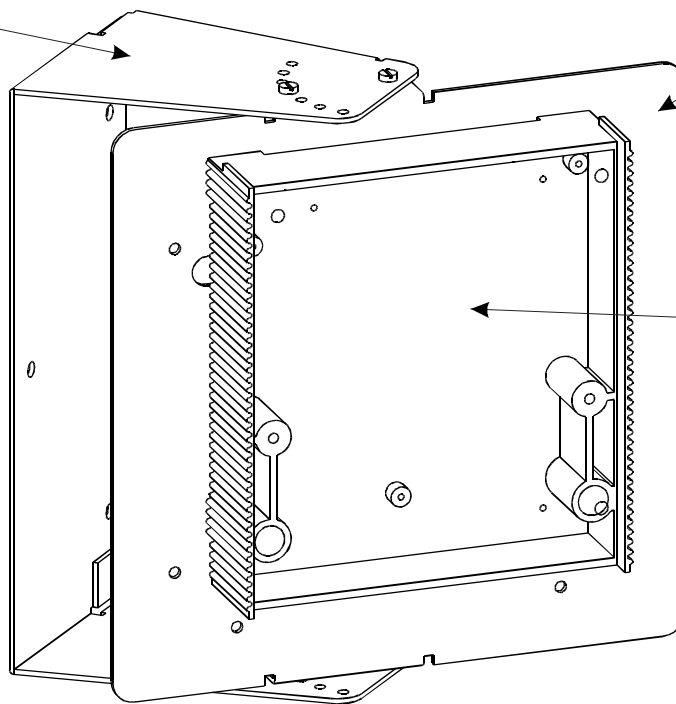

Orientation Kit Back Plate
Mounting onto pivot bracket
4 x M4x10 pan head screws

Detector base mounting onto
orientation kit back plate
3 x M4x20 Pan head screws
3 x M4 Nuts
3 x M4 Washers

PIVOT BRACKET WALL MOUNTING

3 x Ø 6 mm holes

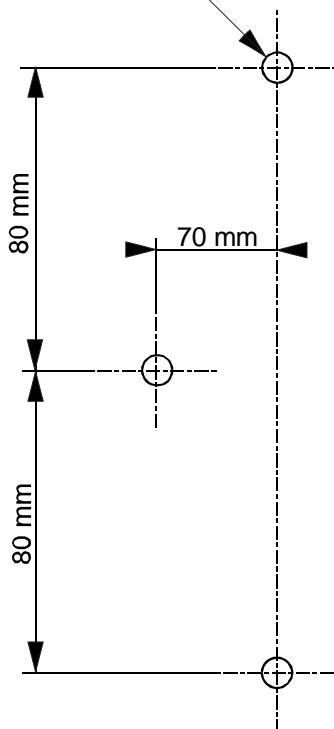

REFL-20 REFLECTOR MOUNTING ONTO 6200-OBK ORIENTATION KIT

30mm Threaded
spacer

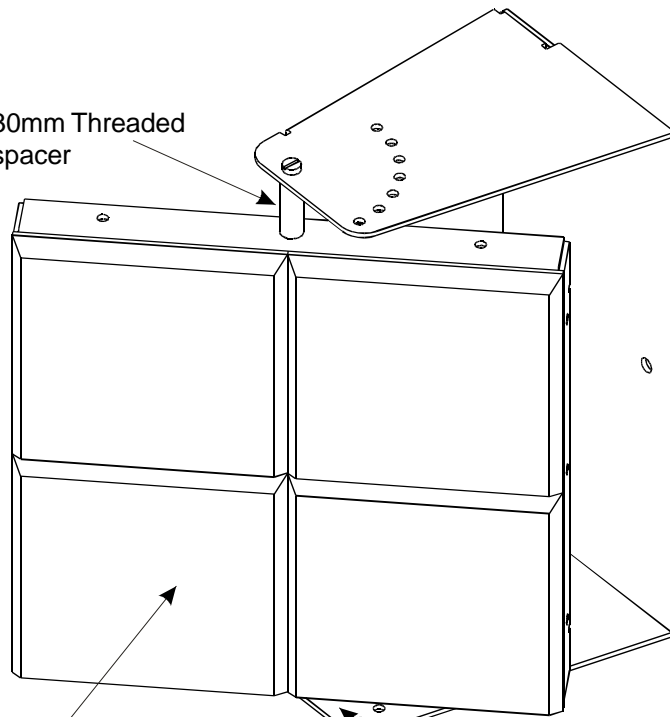

REFL-20 Reflector mounted to
pivot bracket:
3 x M4x10 Pan head screws
1 x M4 Nut
1 x M4x30mm Threaded Spacer
M4 Lockwasher

Lockwasher fitted
between pivot bracket
and reflector