

Arming

After switching off the ignition, removing your key and exiting the vehicle, close all the doors (closing of all windows is also recommended). Arm the car alarm by pressing the button on the remote control.

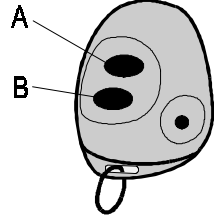

If you press **button A** the car alarm will be armed completely **with ultrasonic, vibration and current consumption detectors**.

The „Accent“ can also be armed **without** the mentioned detectors by **button B** (when you leave a dog in the car for example).

One flash from the turn lights and one siren chirp* confirms arming (the sounds for button A and B are different), and the LED starts to flash. At the same time the immobilizer is blocked and the doors should automatically lock (if equipped with central-door locks). If a powered window control system is also connected to the „lock“ signal, all the windows will be closed automatically* when button A is used for arming (button B arming does not have any influence on the windows).

The current consumption detector will be active 10 minutes after arming. All the other sensors will come on line after seven seconds.

If you hear **four fast siren chirps when arming**, it indicates that an input is activated (for example a door is not closed properly). This input will be disabled automatically. The LED will indicate this fact after disarming in the same manner as alarm memory.

AUTOIMMO*

will block the car automatically if ignition key is turned off for more than 5 minutes. This immobilization (car alarm stays disarmed) is indicated by intermittent LED light. The immobilization can be switched off by a remote control button (A or B). It will also switch off if you switch on the ignition key and press the VALET button*.

Automatic immobilization can also be temporarily disabled if you switch off the ignition key while the VALET button is pressed. The AUTOIMMO function will be disabled until the remote control is activated again. This can be used, for example, when you leave your car in a car shop for maintenance without the remote control.

Disarming

To disarm the car alarm press a button (either A or B) on the remote control once.

The turn lights should flash twice and the siren should chirp twice*. At the same time the doors should unlock (if equipped with central-door locks) and the LED should turn off. When you open a door the dome light will come on for 60 seconds or until you switch on ignition key.

Rearm* - if you do not enter the car within one minute after disarming, the car alarm will rearm and lock the doors automatically again.

If the lights flash three times, the siren chirps three times and the LED continues to flash, it indicates **Alarm Memory** (the alarm was triggered since it was turned on). The LED alarm memory indication is switched off after switching on the ignition key. You can learn what was the last alarm reason, anytime when you press A button on the remote control while the ignition key is on (or the second from last alarm reason with B button). You can see which input triggered the alarm from the LED blinking (see the following table).

number of flashes	what triggered the Alarm
2	attempt to switch on ignition
3	door switches
4	AL1 trigger input
5	AL2 trigger input
6	current consumption detector
7	vibration detector CA-320 only
8	ultrasonic detector CA-320 only

Alarm

In alarm mode the siren sounds for 30 sec., the turn lights flash for 60 sec. and the pager transmits (if installed). The car doors are automatically re-locked in the beginning and in the end of each alarm period to insure that the car will remain locked after an event which triggers the alarm.

The remote control may be used to stop triggered alarm by pressing a button (either A or B). If you stop the alarm with the remote control, the car alarm will remain armed. To disarm it, press a button once more. Three flashes and chirp sounds will confirm the alarm has been disarmed after alarm.

Panic Alarm*

Can be triggered any time if A&B buttons are pressed simultaneously for more than 0.5 second. The siren sounds and the turn lights flash for 30 seconds. The Panic Alarm can be stopped by pressing a remote control button (A or B).

Note: Panic Alarm is not stored into the alarm memory.

Emergency Disarming*

If you lost your remote control, perform following: Open the car door (this triggers the alarm), switch on the ignition key and press the hidden VALET switch.

Note: If emergency disarming was disabled in setting mode, there is no way to disarm the car alarm (call service).

No reaction of Car alarm to remote control

If there was any attempt to scan the remote control code (or while rare, as may happen after the remote control battery has been replaced) then the car alarm will not respond to the signal from the remote control. In this case the alarm asks you for a confirmation of control code validity.

To provide, make Emergency Disarming (if armed), switch on the ignition key and press the button of the remote control (A or B). After that the remote control should work as usual (if not, go to service).

Note: this way your system performs more complicated analyses of coding system. It insures your alarm is secure from outside interference and the remote control is indeed yours.

Maintenance

There is no special maintenance required. If the distance from your car at which the alarm system can be operated continuously decreases, then replace the remote control battery (after releasing of a screw on the rear side of remote control housing; mind the battery polarity). A suitable replacement battery is L1016 (6VDC). Usual good battery life time is one year.

We recommend a yearly professional inspection of the car alarm. Periodic inspections should be made to the door, hood and trunk switches.

We recommend installer to give a detail explanation of „Accent“ functions to the customer after installation, to avoid problems and misunderstandings in future.

* these functions are selectable in setting mode



JABLOTRON Ltd.

Czech republic

E-mail : alarm@jablotron.cz

http://www.jablotron.cz

Installation

The car alarm will work only if properly installed. Improper installation of the car alarm can result in poor and/or dangerous car performance. We recommend having the alarm professionally installed.

INSTALLATION INSTRUCTIONS: Disconnect the battery before starting installation. Keep in mind that if your car has some memory functions, these may be erased if you disconnect the battery. Nobody should be inside the car equipped with airbags when connecting or disconnecting the battery. Refer to the car owners' manual before disconnecting the battery.

Install the control unit in the passenger compartment. The recommended location is under the dash board. The wire coming directly from the control unit is the remote control antenna. The location of this wire will effect the remote control working distance. Ideally, the wire should be near a window. If you drill a hole in the car, be sure to check the area before drilling to prevent damage to the car.

Ultrasonic detector - (CA-320 only) install the ultrasonic sensors in the passenger compartment so that the sensors have an unobstructed „view“ of the compartment. Suitable locations for the sensors are on the top of the front window pillars. Install one sensor near the upper left corner of the front window, the second one near the upper right corner of the window. The front of the sensors (covered with a metal grid) should be oriented towards the center of the rear window.

Route the sensor cables to the processing unit and connect the corresponding color connectors. The „Accent“ automatically calibrates itself according to the size of the vehicle. If you install sensors into an extremely small passenger compartment (driver compartment of a van for example), we recommend that the jumper located between the ultrasonic sensors' connectors on the car alarm unit be disconnected. When this jumper is disconnected, the initial level of the sensitivity is lower. No other adjustment of the ultrasonic detector is required.

Vibration detector - (CA-320 only) is built into the main unit. Its sensitivity is factory adjusted. If the detector is used as alarm trigger (see setting mode), it will trigger the alarm only if multiple vibrations is detected (built-in digital filter). If the detector is set as a warning trigger, each vibration will cause a siren chirp and a blinker flash (when armed). Arming of the vibration detector is optionally selected when arming the car alarm, and can also be disabled completely in the setting mode.

Current detector - will trigger ALARM if an electrical device of the car is switched ON while the „Accent“ is armed. Sensitivity of this detector depends on the car battery conditions. The current sensor activates 10 minutes after arming (to prevent the cooling system fan from triggering the alarm). Arming of the current detector is optionally selected when arming the car alarm, and can be also be disabled completely in the setting mode.

Note: all the above built-in detectors are active only if the system is armed by the A button on the remote control.

LED indicator is on a separate cable. Once you have determined the position on the dashboard where you want the LED light, drill a 6.5mm (4/16") diameter hole in the dashboard and install the LED. Be sure to check for other cables before you drill the hole. Connect the LED cable into any of the three pin connectors on the main unit.

VALET Switch - has a separate cable. This push button switch can be used as an executive override if the remote control is lost. However, if the VALET switch was optionally disabled in setting mode, it will not be able to override. Find a hidden place in the car and install the switch. Connect the cable to any of the three pin connectors on the main unit.

WIRING - route wires for the car alarm with the electrical harness of the car. Check each connection made to ensure that it is solid and properly insulated. Use only a real crimping tool to make connections. Complete and check all wiring before switching on the power.

RED = Positive Supply - connect this red wire to a direct line from the positive terminal of the battery. This wire is split in the car alarm wire harness. The loop with the fuse (10Amp), is a separate power supply for turn lights. The fuse protects against a short connection of the turn indicator bulb. Use only a 10A fuse in this harness!

BLACK = Grounding - connect this wire to the original GND point in the car.

BLUE/WHITE = ARM signal (power for external detectors) provides voltage +12V while the alarm is ARMED (by button A). The maximum load of this output is 25mA.

The „Accent“ brand name system is suitable for all cars equipped with 12V voltage and a negative ground. This car alarm is remotely controlled. RF communication is protected by a FLOATING digital code and by an ANTI-SCAN feature. The CA-321 model is a simplified version without built-in ultrasonic and vibration detectors. All other features are identical.

Arming and disarming of the system is confirmed by the turn indicators blinking and by a siren chirp (selectable). While the ignition key is on, the system can not be armed. This protects the car from having the alarm accidentally activated while driving. A visual warning of the presence of the alarm is provided by an LED indicator, which also provides an "Alarm memory" function, indicating which input was triggered.

Door lock outputs allow the central locking system to be controlled by the remote control (programmable output pulse duration). A signal to close electrically powered windows is also available.

A built-in current sensor will trigger the alarm if any electrical equipment is switched ON while the „Accent“ is armed. The current sensor activates 10 minutes after arming. This prevents the cooling fan from triggering the alarm. Arming of the current sensor is optionally selected when arming the car alarm, and can also be disabled completely in the setting mode.

A built-in ultrasonic detector (CA-320 only) protects the passenger compartment. It detects any movement in the protected airspace. When the „Accent“ is not armed, the ultrasonic generator is turned off. This protects the passengers from unnecessary ultrasonic bombardment. Arming of the ultrasonic sensor is optionally selected when arming the car alarm.

A built-in vibration detector (CA-320 only) has a digital filter which provides immunity to false alarms. This detector has selectable functions for warning or alarm triggers. Arming of the vibration detector is optionally selected when arming the car alarm, and can also be disabled completely in the setting mode.

The „Accent“ can be armed without the ultrasonic, vibration and current detectors by pushing button B on the remote control.

An automatic Dome light control is provided by an extra door switch input/output (negative trigger). It turns ON the dome light after disarming and the opening of any door. The light will remain ON until you switch ON the ignition (max. 60 sec.).

The car alarm contains two independent trigger inputs (AL1 and AL2). The AL1 is a negative alarm trigger, and the AL2 provides selectable polarity and reaction (alarm or warning).

When the armed system is triggered, there can be two different reactions. Warning - a short siren and blinkers signal (0.5 sec.) or ALARM - siren sounds for up to 30 seconds and the turning indicators flash for 60 seconds. An optional wireless pager can be connected (PG-2W). Panic alarm can also be triggered by remote control.

A built in powerful immobilizer (3 relay contacts) can disable important systems (starter, ignition, electrical fuel pump etc.).

The „Accent“ provides optional REARM and AUTOIMMO functions. REARM checks if the car has been entered within one minute of disarming. If not, the alarm is automatically rearmed and the doors are locked again. AUTOIMMO function will block the car automatically if ignition key is turned off for more than 5 minutes. Optional functions can be modified in setting mode by a professional mechanic after installation.

Specifications

voltage	10 - 16VDC
stand by consumption (incl. ultras.)	max. 20mA
working temperature	-40 to +85°C
remote controller distance	max. 20m
remote controller	equipped with SAW resonator
coding	digital floating code system with Anti-scan
siren output	+12V, max. 1.2A
turn indicator outputs	2 x +12V, max. 2 x 5A
central lock outputs	pulses to GND, max. 300mA, 0.3 - 4sec.
optional „lock“ signal duration (for el. powered windows)	60sec.
ARM signal (for external detectors)	+12V, max. 25mA
immobilization relay contacts (3 loops)	max. 15A permanently max. 20A for 30 seconds

AUX output	digital bus output (future use)
current sensor	10 min. exit delay
vibration detector*	digital filter, Warning or Alarm
ultrasonic detector*	automatic sensitivity control, 2 levels
negative switched door contacts	inp. / courtesy light outp. 10W
AL1 negative trigger alarm input	N.O. sensor
AL2 trigger input	selectable polarity, Warning or Alarm
VALET push button	executive override, setting
All the data is stored to EEPROM memory.	
This product complies with E/CE/324/1/96.	

* model CA-320 only

WHITE/BLACK = Lock, WHITE/BLUE = Unlock - these wires provide signals to control the central door lock system. The maximum output current for either of these lines is 300mA. NPN transistors switching to the GND are on the output of these lines. The duration of output pulses is programmable (0.3sec. factory default). Connect the wires from the „Accent“ to the inputs of the central locking system control unit.

If the car has powered windows with a "close all windows" button you can use the „Lock“ signal to close all the windows. In this case, select the longer "Locking Signal" in the setting mode. This way the car alarm will lock the doors and will close all windows if button A is used for arming and it will only lock the doors if button B is used.

Do NOT connect the wires from the car alarm directly to the actuators! See "Examples of Accent use for different central locking systems" if your locking system uses another type of control signals. If you are also going to install a central locking system in your car, we recommend the CL-20A.

BLUE = Ignition Key Input - connect the blue wire to the ignition key switch (+12V when ignition is ON). This signal will prevent accidental arming of the alarm while driving and resets the alarm memory. It will also trigger an alarm if someone switches ON the ignition without first disarming the car alarm. This signal is also used for other functions (REARM, AUTOIMMO, Alarm Memory reading, etc.).

Note: Be sure, that +12V is also present, when a starter is used.

GRAY = Door Switches input, Dome Light Control output - is a negative alarm trigger input. It also functions as the dome light control output. Connect this wire to the door switches (we recommend to have switches installed in all doors). When a door opens, and the central control unit is armed the alarm will be triggered. With the system is disarmed, opening the door turns on the interior dome light till the ignition key is switched on (max. 1 minute).

NOTE: The maximum load of the interior light can be 10W.

WHITE = AL1 Alarm Negative Trigger input will generate an alarm if grounded. It can be used for any additional detector.

YELLOW/WHITE = AL2 Trigger input has selectable trigger logic (can be activated when connected to ground or when disconnected from the ground). The kind of reaction (Alarm or Warning) can be customized for this input in setting mode. An additional sensor can be connected to this wire.

Note: each of the above inputs can only trigger alarms a maximum of three times during each arming period.

YELLOW = Siren - is the siren output (+12V, max. 1.2A). Mount the siren in the engine compartment, with its negative pole to ground. Connect the positive pole of the siren to this wire.

A pager transmitter can also be triggered by the siren output. We recommend model PG-2W.

Notice : No additional siren can be connected to the car alarm siren output.

VIOLET = Turn Indicators - the two violet wires provide power for the left and right turn indicators. Each wire provides 12V, 5A pulses to the lights as a visual indication of arming, disarming and alarm triggering. Connect one of the violet wires to the left turn light and the other violet wire to the right turn light. These two wires also work as inputs to disable the built-in current sensor. The car alarm can be armed even if the flashing emergency lights are ON (flashing of all turn indicators).

Immobilization - the six wires in a separate connector are the three built-in immobilization contacts' leads. Each wire is marked by a number on its end (remove the numbers after installation). The following wires are connected by internal relay contacts inside: 1-3, 2-4, 5-6. The starter, fuel pump, ignition or any other system that when electrically disconnected will render your car inoperative, may be connected here. Only disarming the alarm and switching ON the key in the ignition closes the contacts. These contacts will operate correctly for permanent load up to 15A, max. 20A for 30 seconds (each).

Adding of a new remote controller

There are two remote controllers in each „Accent“ car alarm set. The car alarm can be operated with a maximum of three remote controllers. To add an additional remote control or to replace an original one (in the case one is lost) perform the following procedure:

Switch on the ignition key when car alarm is disarmed and press the hidden VALET button five times (in 1 minute from the moment when you turned on the ignition). The siren will make two long signals and the LED will light continuously. The control unit is now in remote control learning mode.

You must activate all remote controls (one by one, button A or B) which you want accepted by the car alarm. The control unit will store codes in its memory (confirmed by a LED flash and for a brand new code also by siren chirp).

Keep in mind that only three controllers can be taught to the car alarm. If you try to teach a fourth controller, the first one will be forgotten and so on. If you activate only one controller in learning mode, you will be able to control the car alarm only with this one controller.

To close learning mode, switch off the ignition key. You can see how many remote controls are available for your car alarm by number of LED flashes every time when you switch on the ignition key.

Setting mode

Optional functions can be modified. To enter the setting mode perform the following procedure:

- press the hidden VALET button when the car alarm is disarmed and hold it pressed
- after 5 seconds (or more) switch on the ignition key
- the siren will make two long and one short signals and the LED will light continuously
- release the VALET button; the car alarm is now in setting mode

Now you can make setting; see the following table (you are in row no. 1). Setting of the parameter is indicated by LED and can be changed by a remote control button (A or B), each short pressing will change the parameter (on - off - on - off - etc.). Bold printed parameters are factory default settings.

To select next parameter (next row in the table), press VALET button quickly. The siren will confirm parameter (row) number by the number of signals. Step by step go through all parameters. When you are on parameter number 13, the next VALET button pressing will store all the programming to the memory and the setting mode will be exited (confirmed by the siren with a long signal). If you switch the ignition key off any time before the setting mode is completed, the setting mode will be terminated and no changes will be stored.

Note: All data is stored to EEPROM memory, so removing power from the car alarm will not change them.

no.	parameter	status (LED)		description
		☼ (on)	● (off)	
1	REARM	enabled	disabled	if car is not entered within 1 min. after disarming, it will arm again
2	AUTOIMMO	enabled	disabled	if enabled it will block engine if ignition key is switched off for more than 5 min.
3	duration of locking pulses	0,3 sec.	4 sec.	modify „lock“ and „unlock“ output pulse duration
4	longer „lock“ signal	60 sec.	normal	the „lock“ pulse is normal (see step no. 3) or longer (60 seconds)
5	emergency disarm with VALET	enabled	disabled	if emergency disarm is disabled, VALET button can only be used for setting (emergency disarm is possible only by a professional mechanic)
6	arming / disarming chirps	all arming	limited	if limited, only B button arming and after alarm disarming is indicated with siren (no sound for A button arming and normal disarming)
7	PANIC alarm	enabled	disabled	can be triggered if A&B buttons are pressed simultaneously
8	current detector	enabled	disabled	possibility to switch the detector completely off
9	vibration detector	enabled	disabled	completely disabled (no function for CA-321)
10	vibration detector reaction	ALARM	WARNING	alarm or short siren chirp only (no function for CA-321)
11	open door warning	enabled	disabled	if disabled, it will not indicate if all the doors are closed when arming (car alarm tests door switches, AL1 and AL2 inputs when arming)
12	AL2 input reaction	ALARM	WARNING	alarm or short siren chirp only (warning)
13	AL2 input logic	N.O.	N.C.	Normally Closed contact logic can be used as a positive trigger input.

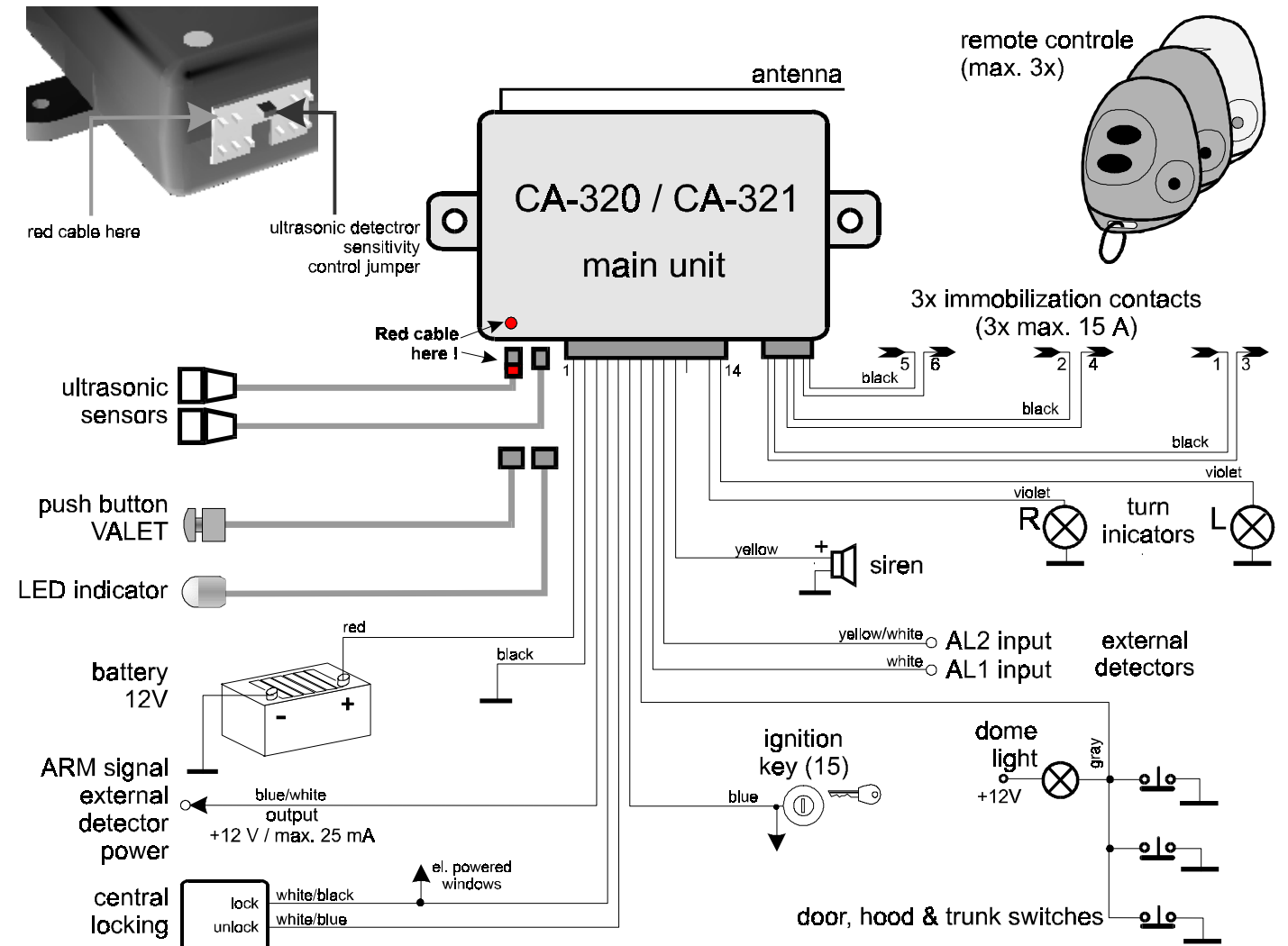

Examples of „Accent“ use for different central locking systems

If your locking system needs another kind of control signal than negative pulses, install a couple of over-switching relays to the „Accent“ outputs (or you can use CR-2 relay unit). See following diagrams for different locking systems.

System with positive control inputs:

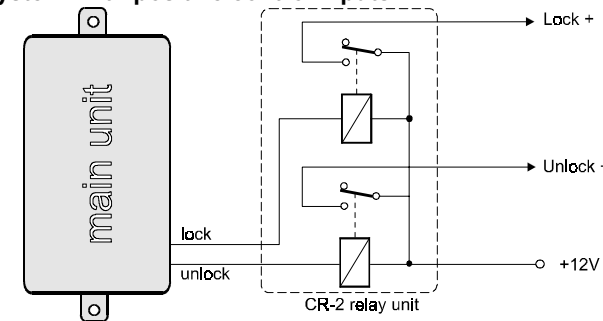

Pneumatic central locking system:

Program duration of output pulses 2 or 4 seconds according to the reaction time of the pneumatic system.

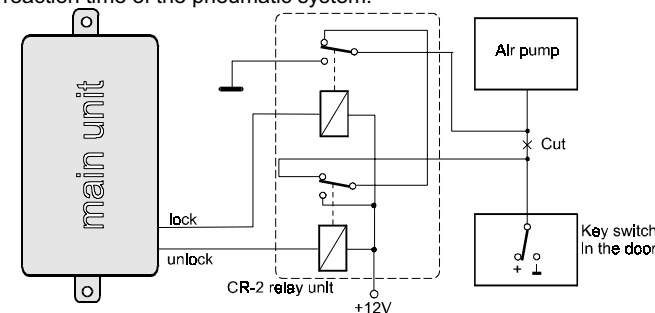

Simplified additional installation of central locking system:

When manual operation of the whole system from the driver's door is not requested, you can use the following easy solution. Install two-wires actuator (recommended type CM-2) to each door of your car. Connect them as shown in the following diagram. Program duration of Accent output pulses 0.3 seconds. This way all actuators are operated with the remote control.

When necessary, the door locks can also be operated manually with a key (the same way as before the central locking installation).

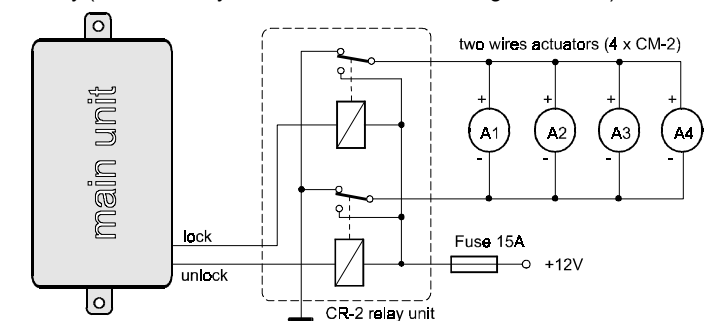

Caution : In this case do not use longer locking signal !